



UNLADEN WEIGHT.

430 kgs.

CARRYING CAPACITY.

1800 Kgs at speeds of 24 km/h

LOAD CAPABILITY.

50 Units of Luggage.

LOAD BED.

Formed 3.0mm galvanised steel load bed inclined towards full-length central drainage channel.

Loading Height from ground: 562mm.

Clear Bed Area : 2418mm x 1510mm.

SUPERSTRUCTURE.

Front & rear end-frames are of welded construction. Robust steel tube is used throughout & both ends securely bolted to chassis.

Choice of height from load-platform surface to top of end-frame 1000mm or 600mm.

RUNNING GEAR.

The Four Wheels are, 15 x 4 1/2 -8 x 3.00D 5.0mm split rims on 3-stage Super Elastic solid rubber tyres.

Owen Holland's unique flange mounted, five stud, taper roller bearing hub system

(separately detachable axle-ends) is used.

STEERING.

On front wheels via Turntable mounted on a heavy-duty, zinc-plated, Ball Bearing ring.

BRAKES.

Highly effective parking brakes operate on the front wheels and are actuated when the tow bar is automatically latched in the raised position or when lowered to the ground.

A foot pedal releases the latch and the brakes are released when the tow bar is lowered to towing height.

CURTAIN CLOSED BAGGAGE TROLLEY

STANDARD COUPLINGS.

Rear-Hitch - 'E' type with captive spring loaded 25mm pin can be retained in upright position for easy coupling.

Tow Bar - is fitted with a grip-handle. The forged steel eye has 50 mm diameter hole and a ring section diameter of 30 mm.

STANDARD FINISH .

Painted as per customer specification
High-Visibility markings on surround-frame corners and both sides of tow-bar

OPTIONS - EXTRAS.

- ➔ Alternative Couplings.
- ➔ Special Corporate or identification markings / Additional visibility markings.
- ➔ 'Blackboard' plate or clear PVC document-pouch on end-frame.
- ➔ One-piece Baggage-Protection Cover with stowage-cradle fixed to end-frame. Tensioners secure Cover at sides/ends.
- ➔ End-Frames in-filled with formed sheet-steel panels.

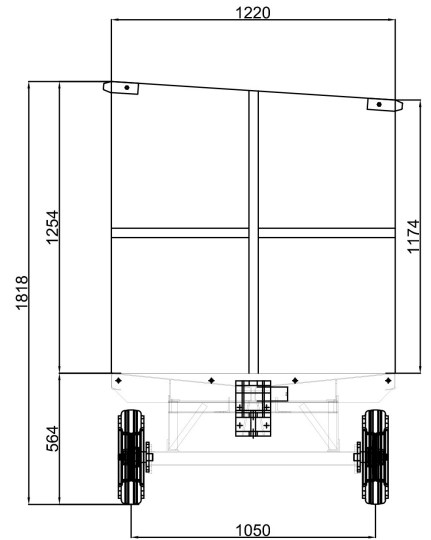
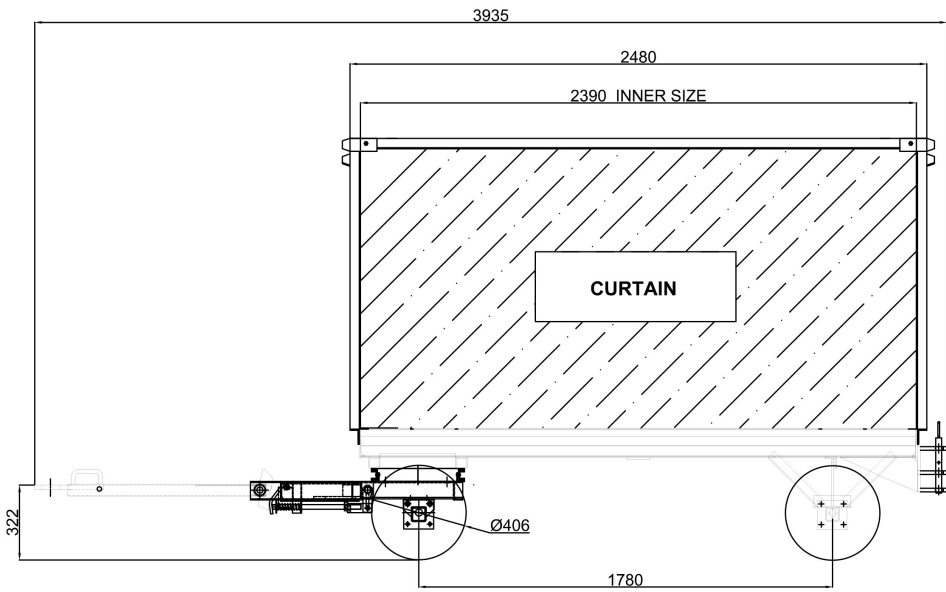

Transtec Overseas Private Limited

70, Podar Chambers, S.A. Brelvi Marg, Fort,
Mumbai - 400 001, Maharashtra, INDIA
Tel: +91.22 2261 8334/8461

Web: www.transtecoverseas.com
Email: info@transtecoverseas.com